



# Company Fact Sheet

## SAP Business ByDesign

Country Version for the US  
Manufacturing and Professional Services  
August 15, 2014



SAP Cloud Reference Systems

## Table of Content

<b>1</b>	<b>Introduction .....</b>	<b>4</b>
<b>2</b>	<b>The Reference Company Almika .....</b>	<b>4</b>
2.1	Company Profile.....	4
2.2	Organizational Details.....	5
<b>3</b>	<b>Master Data in the System.....</b>	<b>6</b>
3.1	Employee Overview .....	6
3.2	Employee Details .....	8
3.2.1	Work Center Assignment.....	8
3.2.2	Organizational Assignment .....	10
3.2.3	Pricing for Model Company Users .....	11
3.3	Service Agent for Partner Development (PDI).....	13
3.4	Customers and Prospects .....	13
3.5	Suppliers.....	15
3.6	Products.....	16
3.7	Services.....	18
3.8	Entitlements.....	19
3.9	Location Layout and Bill of Material.....	20
3.9.1	Location Layout.....	20
3.9.2	Bill of Material Overview .....	21
<b>4</b>	<b>Transactional Data in the System.....</b>	<b>23</b>
4.1	Document Flow for SRM .....	23
4.2	Document Flow for CRM.....	24
4.3	Document Flow for Projects .....	25
<b>5</b>	<b>Sample Data for Specific Functions.....</b>	<b>26</b>
5.1	Outbound Delivery with UPS/FedEx Tracking Number.....	26
5.2	Demand Plans with Forecasts .....	26
5.3	Sales Order for Genealogy Inquiry .....	26
5.4	Customer Contract.....	26
5.5	Supplier Contracts .....	27
5.6	Material for Cycle Counting .....	27
5.7	Product Model Showing all Product Property Formats .....	28
5.8	Product Specification .....	28
5.9	Projects.....	28
5.10	Project Templates .....	28
5.11	Predefined Mass Data Run Objects (MDROs) .....	29
5.12	G/L Account Mapping .....	29
<b>6</b>	<b>Important System Settings .....</b>	<b>31</b>
6.1	Number Ranges.....	31
6.2	Approval Limits.....	32



# 1 Introduction

This document provides essential information for anyone intending to test or execute business tasks in a reference system of SAP Business ByDesign. The following chapters give you detailed insight into the fictitious business environment that was set up for this reference system.

The first part of this document outlines the facts and characteristics of the model company ALMIKA that uses SAP Business ByDesign for their business.

The second part of the company fact sheet contains all of the master data and transactional data that has been set up in the reference system for you. This built-in sample data enables you to use the SAP Business ByDesign reference system for demo and test purposes without first having to upload your own data.

## 2 The Reference Company Almika

### 2.1 Company Profile

ALMIKA is a fictitious model company which helps to illustrate a realistic business environment including end-to-end business processes in the SAP Business ByDesign Reference System.

The enterprise operates through two lines of business:

- In the manufacturing line of business the company's focus is the production and wholesale of commercial and residential heating equipment. The residential heating equipment is distributed as standardized and specified products.
- In the service line of business the company provides IT products and services. This includes consulting and software as well as customer service.

While the more administrative functions (financial accounting, human resources management, purchasing) for the complete company are bundled in a shared services department, separate customer help desks are set up for each line of business.

ALMIKA is located in the US and has business locations in:

- Cleveland, Ohio (Headquarter and Manufacturing)
- Canton, Ohio (Professional Services)
- Toledo, Ohio (External Warehouse)
- Cleveland, Ohio (Outsourcing Warehouse)
- Fresno, California (Sales/Consulting Office)

The company was founded in 1954 and started as a producer of commercial heating equipment.



The service-oriented line of business started in 1983 after the acquisition of an IT company. The company has approximately 80 employees and its annual revenue is about 12 million USD. To ensure compliance in an international environment, ALMIKA runs the following parallel accounting principles:

- US GAAP
- IFRS

INNOVAT Inc. is a small affiliated company with a portfolio of products and services similar those that ALMIKA offers. It belongs to the same holding and exchanges both products and resources with ALMIKA using intercompany processes.

## 2.2 Organizational Details

The graphic below gives you a high-level overview of the organizational structure of ALMIKA.

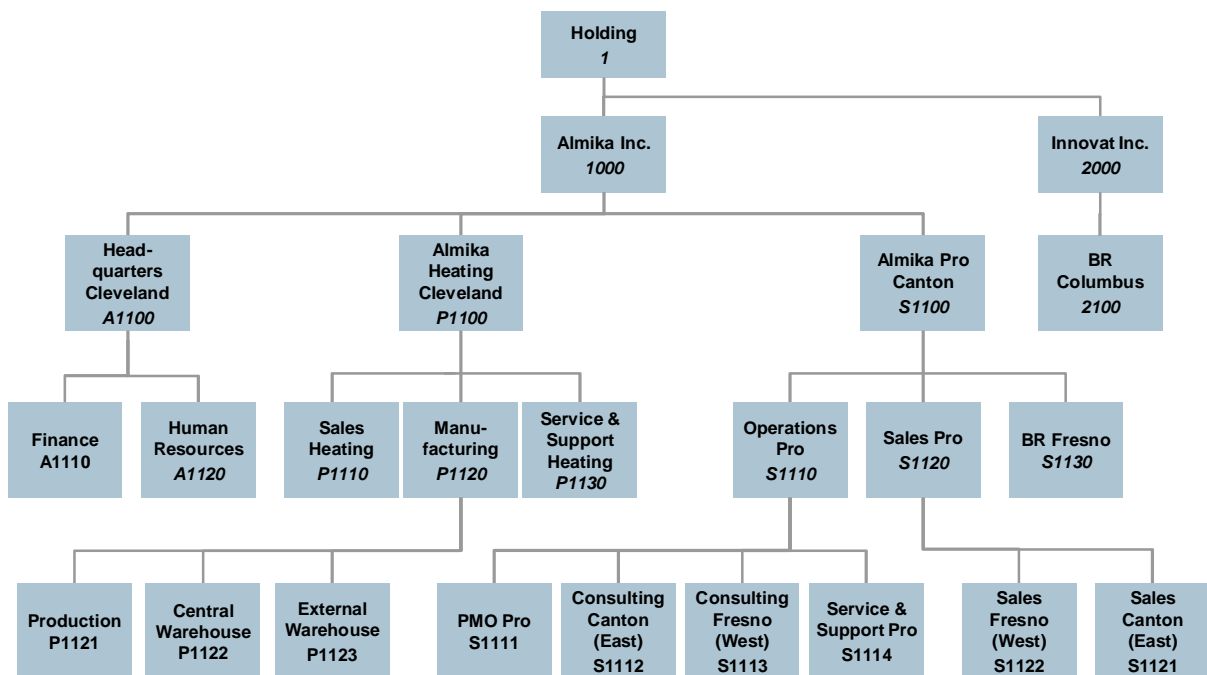

## 3 Master Data in the System

### Considerations on the Naming Convention for Master Data

The model company ALMIKA has two lines of business, which is reflected in a specific naming convention that helps to differentiate master data in certain areas. Each line of business has its own naming convention, for example, for user names and other master data. The respective naming convention is outlined after each of the master data sections where a differentiation is required.

#### General Guideline

All manufacturing-specific alphanumerical master data starting with „P“

All service-specific alphanumerical master data starting with „S“

All cross master data starting with „A“

### 3.1 Employee Overview

#### Naming convention for user IDs

- LoB Manufacturing: SALES01P, SALES02P, ...
- LoB Services: SALES01S, SALES02S, ...
- Shared services: FINANCIAL01, ...
- Second company: CEO91, SALES91, ...

#### Naming convention for employee IDs

- LOB Manufacturing: E0102, ...
- LOB Services: E0201, ...
- Shared services: E0001, ...
- Second company: E1001, ...

#### LoB Manufacturing

User ID	Role	Last Name	First Name	Employee ID
CEO01	Chief Executive	Kennedy-Woods	Catherine	E0001
SALES02P	Sales Representative	Jacob	Kate	E0103
MARKETING02P	Sales Representative	Johnson	Michelle	E0104
SUPPLYPLANNER01P	Production Manager	Stone	Richard	E0105
PRODUCTENGINEER02P	Product Engineer	Eycken	Erin	E0106
PRODUCTIONPLANNER01P	Production Planner	Wolfe	Samantha	E0107
PRODUCTION02P	Production Operator	Peacock	Michael	E0108
WAREHOUSE02P	Warehouse Operator	Smith	Mark	E0110
WAREHOUSE01P	Warehouse Manager	Loblanski	Luther	E0109
WAREHOUSE03P	Warehouse Operator	Mornay	Henry	E0111
SALES01P	Sales Manager	Menson	Bob	E0102
SERVICEPLANNER01P	Service Order Planner	Ingersoll	Jack	E0112
SERVICEDESK02P	Service Employee	Puente	Carla	E0113

User ID	Role	Last Name	First Name	Employee ID
SERVICEENGINEER02P	Service Engineer	Wellington	Martin	E0114
DIRECTOR01P	Division Manager	Carlson	Vincent	E0101
BASICCRM02P	Sales Representative	Jennifer	Miller	E0116

## LoB Services

User ID	Role	Last Name	First Name	Employee ID
DIRECTOR01S	Division Manager	Taylor	Greg	E0201
PROJECTS01S	Consulting Manager	Sellers	Peter	E0202
SALES01S	Sales Manager	Johnson	Roberta	E0203
PROJECTS02S	Consultant	Gartner	Tonia	E0204
PROJECTS03S	Consultant	Newman	Robert	E0205
CONSULTANT01S	Service Employee	Winters	Susan	E0206
CONSULTANT02S	Service Employee	Ducan	Robert	E0207
CONSULTANT11S	Service Employee	Jackson	Jane	E0208
CONSULTANT12S	Service Employee	Butler	Albert	E0209
SALES02S	Sales Representative	Brannon	Victoria	E0210
MARKETING02S	Sales Representative	Jagger	Kathy	E0211
SERVICE01S	Service Employee	Holmes	Alicia	E0212
SERVICEDESK02S	Service Employee	Candela	Martin	E0213
SERVICESUPPORT02S	Service Employee	Polley	Briana	E0214

## Shared Services

User ID	Role	Last Name	First Name	Employee ID
FINANCIAL01	Chief Financial Officer	Black	Edward	E0002
FINANCIAL02	Accountant	Green	Iris	E0003
PURCHASE02	Buyer	Warner	Bill	E0004
HRM02	HR Administrator	Flahan	Peter	E0006
ADMINISTRATION01	System Administrator	Smoke	Eddie	E0005
QUALITYENGINEER01	Quality Engineer	Marlow	Ben	E0117

## Second Company

User ID	Role	Last Name	First Name	Employee ID
CEO91	Chief Financial Officer	Howard	Kevin	E1001
CONSULTANT91	Consultant	Tompson	John	E1002
SALES91	Sales Representative	Sell	Katie	E1003
WAREHOUSE91	Warehouse Operator	Jones	Chris	E1004
FINANCIAL91	Accountant	Smith	Martha	E1005

## PDI Partner Development

User ID	Role	Last Name	First Name	Employee ID
XXXXXXXXXXXX	PDI development user	PDI	USER	

### 3.2 Employee Details

#### 3.2.1 Work Center Assignment

Overview of the model company's employees and the Work Centers they are authorized to use:

Work Center	CEO01	FINANCIAL01	FINANCIAL02	PURCHASE02	ADMINISTRATION01	HRM02	AUDITOR	QUALITYENGINEER01	DIRECTOR01P	SALES01P	SALES02P	BASICCRM01P	MARKETING02P	SUPPLYPLANNER01P	PRODUCTENGINEER02P	PRODUCTIONPLANNER01P	PRODUCTION02P	WAREHOUSE01P	WAREHOUSE02P	WAREHOUSE03P	SERVICEPLANNER01P	SERVICEDESK02P	SERVICEENGINEER02P	EXTCONSULTANT01P
Account Management					x					x	x	x	x											
Application and User Management					x	x		x																
Audit		x			x			x																
Business Analytics					x																			
Business Configuration					x			x																
Business Partner Data					x	x						x												
Compensation					x	x																		
Corporate Performance	x	x			x																			
Cost and Revenue	x	x	x		x					x	x													
Customer Invoicing		x	x		x					x	x			x							x			
Data Privacy Management					x	x																		
Demand Planning					x								x											
E-Commerce																								
Execution					x			x								x		x	x					
Field Service and Repair					x																x		x	
Fixed Assets		x	x		x																			
General Ledger	x	x	x		x					x			x											
Goods and Services Receipts					x	x																		
Inbound Logistics					x			x						x				x		x				
Internal Logistics					x			x										x		x				
Inventory Valuation		x	x		x								x					x						
Liquidity Management		x	x		x																			
Managing My Area	x	x			x					x	x						x				x			
Marketing					x					x	x	x	x											
Mobile Execution					x														x					
New Business					x					x	x	x	x	x										
Organizational Management	x				x	x																		
Outbound Logistics					x			x										x			x			
Outbound Logistics Control					x													x						
Over-the-Counter Sales					x						x													
Payables		x	x		x																			
Payment Management		x	x		x																			
Payroll Processing		x			x	x																		
Personnel Administration		x			x	x																		
Physical Inventory					x																			
Planning and Production Master Data					x			x						x	x	x								
Product and Service Portfolio	x	x	x	x	x					x	x	x									x			
Product Data					x			x																
Product Development					x			x																
Product Portfolio		x	x	x	x																			
Production Control					x			x																
Project Management	x				x			x		x														
Project Team					x			x			x													x
Purchase Requests and Orders		x		x	x			x																
Quality Control					x			x																
Quality Planning					x			x																
Receivables		x	x		x					x														
Recourse Management					x	x																		
Sales Orders					x			x		x	x													
Service Desk					x																	x	x	x
Service Entitlements					x						x											x		x
Service Orders					x						x											x	x	x
Sourcing and Contracting		x		x	x																			
Supplier Base					x	x																		
Supplier Invoicing		x	x		x																			
Supply Chain Design Master Data					x			x																
Supply Control					x			x																
Supply Planning					x					x														
Tax Exemption Configuration		x	x		x																			
Tax Management		x	x		x																			
Third-Party Logistics					x																			
Third-Party Order Fulfillment		x	x	x	x					x	x													
Time Administration					x	x																		
Travel and Expenses		x	x		x																			
Warehouse and Logistics Master Data					x			x																



Work Center Assignment (Table 2)

Work Center	DIRECTOR01S	PROJECTS01S	PROJECTS02S	PROJECTS03S	CONSULTANT01S	CONSULTANT02S	CONSULTANT11S	CONSULTANT12S	EXTCONSULTANT01S	SALES01S	SALES02S	MARKETING02S	SERVICE01S	SERVICE02S	SERVICESUPPORT02S	CEO01	FINANCIAL01	CONSULTANT01	SALES01	WAREHOUSE01
Account Management										X	X	X	X						X	
Application and User Management																				
Audit																	X			
Business Analytics																				
Business Configuration																				
Business Partner Data																				
Compensation																				
Corporate Performance																	X			
Cost and Revenue	X									X						X	X			
Customer Invoicing		X								X	X		X			X	X		X	
Data Privacy Management																				
Demand Planning																				
E-Commerce																				
Execution																				
Field Service and Repair						X							X		X					
Fixed Assets																	X	X		
General Ledger																X	X			
Goods and Services Receipts		X																		
Inbound Logistics																				X
Internal Logistics																				X
Inventory Valuation																	X			X
Liquidity Management																	X			
Managing My Area	X	X								X			X			X	X			
Marketing										X	X	X	X						X	
Mobile Execution																				
New Business										X	X	X	X						X	
Organizational Management																				
Outbound Logistics																				X
Outbound Logistics Control																				X
Over-the-Counter Sales																				
Payables																	X	X		
Payment Management																	X	X		
Payroll Processing																		X		
Personnel Administration																		X		
Physical Inventory																				X
Planning and Production Master Data																				
Product and Service Portfolio	X									X	X		X				X		X	
Product Data																				X
Product Development																				X
Product Portfolio																				
Production Control																				X
Project Management	X	X																X		
Project Team		X	X	X	X	X	X	X	X									X		
Purchase Requests and Orders		X																X		
Quality Control																				X
Quality Planning																				X
Receivables																	X	X		
Recourse Management		X																		
Sales Orders										X	X		X							
Service Desk													X	X	X					
Service Entitlements										X	X	X			X					
Service Orders													X	X	X				X	
Sourcing and Contracting																	X			
Supplier Base																				
Supplier Invoicing																	X	X		
Supply Chain Design Master Data																				X
Supply Control																				X
Supply Planning																				X
Tax Exemption Configuration																				
Tax Management																	X	X		
Third-Party Logistics																				
Third-Party Order Fulfillment																				
Time Administration																				
Travel and Expenses																		X		
Warehouse and Logistics Master Data																				X

### 3.2.2 Organizational Assignment

Employee ID	First Name	Last Name	Job	Organizational Unit ID	Organizational Unit
E0001	Catherine	Kennedy-Woods	Chief Executive Officer	A1100	Headquarters Cleveland
E0002	Edward	Black	Chief Financial Officer	A1110	Finance
E0003	Iris	Green	Accountant	A1110	Finance
E0004	Bill	Warner	Buyer	A1110	Finance
E0005	Eddie	Smoke	System Administrator	A1110	Finance
E0006	Peter	Flahan	HR Administrator	A1120	Human Resources
E0101	Vincent	Carlson	Division Manager	P1100	Almika Heating Cleveland
E0102	Bob	Menson	Sales Manager	P1110	Sales Heating
E0103	Kate	Jacob	Sales Representative	P1110	Sales Heating
E0104	Michelle	Johnson	Sales Representative	P1110	Sales Heating
E0105	Richard	Stone	Production Manager	P1120	Manufacturing
E0106	Erin	Eycken	Product Engineer	P1120	Manufacturing
E0107	Samantha	Wolfe	Production Planner	P1121	Production
E0108	Michael	Peacock	Production Operator	P1121	Production
E0109	Luther	Loblanski	Warehouse Manager	P1122	Central Warehouse
E0110	Mark	Smith	Warehouse Operator	P1122	Central Warehouse
E0111	Henry	Mornay	Warehouse Operator	P1123	External Warehouse
E0112	Jack	Ingersoll	Service Order Planner	P1130	Service & Support Heating
E0113	Carla	Puente	Service Employee	P1130	Service & Support Heating
E0114	Martin	Wellington	Service Engineer	P1130	Service & Support Heating
E0201	Greg	Taylor	Division Manager	S1100	Almika Pro Canton
E0202	Peter	Sellers	Consulting Manager	S1110	Operations Pro
E0203	Roberta	Johnson	Sales Manager	S1121	Sales Canton (East)
E0204	Tonia	Gartner	Consultant	S1111	PMO Pro
E0205	Robert	Newman	Consultant	S1111	PMO Pro
E0206	Susan	Winters	Service Employee	S1112	Consulting Canton (East)
E0207	Robert	Ducan	Service Employee	S1112	Consulting Canton (East)
E0208	Jane	Jackson	Service Employee	S1113	Consulting Fresno (West)
E0209	Albert	Butler	Service Employee	S1113	Consulting Fresno (West)
E0210	Victoria	Brannon	Sales Representative	S1121	Sales Canton (East)
E0211	Kathy	Jagger	Sales Representative	S1122	Sales Fresno (West)
E0212	Alicia	Holmes	Service Employee	S1114	Service & Support Pro
E0213	Martin	Candela	Service Employee	S1114	Service & Support Pro
E0214	Briana	Polley	Service Employee	S1114	Service & Support Pro
E1001	Kevin	Howard	Chief Financial Officer	2100	BR Columbus
E1002	John	Tompson	Consultant	2100	BR Columbus
E1003	Katie	Sell	Sales Representative	2100	BR Columbus
E1004	Chris	Jones	Accountant	2100	BR Columbus
E1005	Martha	Smith	Warehouse Operator	2100	BR Columbus
E0116	Jennifer	Miller	Sales Representative	P1110	Sales Heating
E0117	Ben	Marlow	Quality Engineer	P1120	Manufacturing

### 3.2.3 Pricing for Model Company Users

SAP Business ByDesign is licensed through annual subscription fees, calculated on a named-user basis, and invoiced quarterly.

Find further information here:

<http://www.sap.com/solutions/products/sap-bydesign/buy-now/pricing/pricing-model.epx>

The Almika Inc. users correspond to the pricing user categories as follows:

#### Project Management Self-Service Users:

- Extconsultant01P
- Extconsultant01S
- Projects02S
- Projects03S
- Consultant01S
- Consultant11S
- Consultant12S

#### SCM Self-Service Users:

- Production02P
- Warehouse02P

#### CRM Sales Team Users:

- Marketing02P
- Marketing02S

#### Standard Enterprise Users:

- Auditor
- CEO01
- Financial01
- Financial02
- Purchase02
- Sales02S
- BasicCRM
- Servicedesk02P
- Servicedesk02S
- Serviceengineer02P
- Servicesupport02S
- Consultant02S
- Consultant91
- Sales91
- Director01P
- Director01S
- CEO91
- Financial91
- Sales01P
- Sales01S
- Service01S
- Serviceplanner01P
- Projects01S
- HRM02

**SCM Enterprise Users:**

- Administration01
- Sales02P
- Supplyplanner01P
- Productionplanner01P
- Productengineer02P
- Warehouse01P
- Warehouse03P
- Warehouse91

### 3.3 Service Agent for Partner Development (PDI)

The following user has been created for administrating, developing, or testing solutions in the SAP Business ByDesign studio:

User ID	Password	Role	Last Name	First Name
PDI	Welcome1	PDI development user	PDI	User

### 3.4 Customers and Prospects

#### Naming convention for customers

- LOB Manufacturing: **CP**<nnnnnn>
- LOB Services: **CS**<nnnnnn>

Same number range across companies; no dedicated number ranges on company level.

Account ID	Account Name	LoB- Specific Information	Comment / Usage
CP100110	Silverstar Wholesale Corp	Production Customer	SALES01P fully maintained Demo Account
CP100120	Luxury Heating & Cooling Co	Production Customer	SALES02P
CP100130	Low Plumbing & Heating	Production Customer	Credit limit set to 4000 USD / SALES01P
CP100140	Heat Transfer Specialists	Production Customer	SALES02P Account with multiple ship-tos
CS200123	Unlimited Electrics	Services Customer	SALES02S
CS200125	High Electronic Technologies	Services Customer	SALES02S
CS200128	William & Sons	Services Customer	Credit limit set to 1000 USD / SALES02S Fully maintained Demo Account
CS200130	Hudson Technologies	Services Customer	SALES01S
CS200134	State Electronics	Services Customer	SALES01S
CP100990	PSA International Canada		
CP100991	Sanitaire chauffage Belgium		
CP100992	Heating Solutions Ireland		
CP100993	HPA Sweden		

Account ID	Account Name	LoB- Specific Information	Comment / Usage
CP100994	Sauter AG Switzerland		
10000000	Almika Inc.	Intercompany Customer	
10000001	Innovat Inc.	Intercompany Supplier	

## 3.5 Suppliers

### Naming convention for suppliers

- S<nnnn>

Same number range across companies; no dedicated number ranges at company level.

Supplier ID	Supplier Name	LoB- Specific Information	Comment / Usage
S100100	IMG Ltd		
S100200	AMS Inc.	Used in LOB Production	
S100300	GSI Inc.	Used in LOB Production	
S100400	Omego	Used in LOB Production	
S100401	Technical Components Inc.	Used in LOB Production	
S100402	Electrical Parts International	Used in LOB Production	
S100500	Smith Inc.	Used in LOB Production	
S100650	Premium Computing Services		Used for Company Services
S100600	Office Deliveries		Used for Company Services
S100700	Miller&Son	Used in LOB Production	
S100800	ABC Cargo Worldwide	Used in LOB Production	Freight Forwarder
S100900	Schweitzer		External Catalog Supplier
S100901	ABM Insurance Inc.		Used for Company Services
S100903	Televista Inc.		Used for Company Services
S100905	Rowel Power Inc.		Used for Company Services
S100907	GWG Real Estate Ltd.		Used for Company Services
S100909	Donovan Marketing		Used for Company Services
S100911	China Import and Retail		Prepared Supplier
S100913	MBI Svenska AB		Prepared Supplier
S200100	Excellent Consulting	Used in LOB Services	
10000001	Innovat Inc.		Intercompany Scenario
S100950	Warehouse Services Inc.		Used for Third-Party Logistics

### 3.6 Products

#### Naming convention for products

- LOB Manufacturing: P100101, P100102, ...

Product ID	Description	Product Category	Purchase	Sales	Production	Identified Stock Type
P100101	Heater (22.8 KW)	Boiler, Heater, Assemblies	✓		✓	
P100109	Cylinder	Cylinder	✓		✓	
P100110	Assembled Cylinder (75)	Cylinder	✓			
P100111	Heater 76	Boiler, Heater, Assemblies	✓			
P100119	Cylinder 76	Cylinder				
P100129	Cylinder 77	Cylinder	✓			Batch
P100201	Control Regulation Unit 75	Electronic Parts	✓	✓		Optional specified stock
P100202	Regulation Unit 90	Electronic Parts	✓	✓		
P100203	Regulation Unit 75	Electronic Parts	✓	✓		
P100205	Regulation Unit 70	Electronic Parts	✓	✓		
P100206	Regulation Unit 80	Electronic Parts	✓	✓		
P100213	Control Regulation Unit 55	Electronic Parts	✓	✓		
P100301	Heater 510	Boiler, Heater, Assemblies			✓	
P100401	Gas Boiler Combi 75	Boiler, Heater, Assemblies	✓	✓	✓	
P100402	Combi 110e	Boiler, Heater, Assemblies	✓	✓		
P100403	Combi 190	Boiler, Heater, Assemblies	✓	✓		
P100404	Combi 111	Boiler, Heater, Assemblies	✓	✓		
P100405	Combi ME	Boiler, Heater, Assemblies	✓	✓		
P100406	Combi T120R	Boiler, Heater, Assemblies	✓	✓		
P100411	Gas Boiler Combi 76	Boiler, Heater, Assemblies	✓	✓		
P100436	Washing Solution	Consumer Products	✓			
P100505	Grey Cast Iron Cylinder	Cylinder	✓			



Product ID	Description	Product Category	Purchase	Sales	Production	Identified Stock Type
P100515	Insulation	Cylinder	✓			
P100701	Paper Corrugated Box (980x550x185mm)	Packaging Material	✓	✓		
P100702	Wooden Pallet (1200mmx1000mm)	Packaging Material	✓	✓		
P100709	Cylinder customized	Cylinder		✓	✓	Optional specified stock
P100710	Cylinder customized Trade	Cylinder	✓	✓		Optional specified stock
P100715	Insulation customized	Cylinder	✓	✓		Optional specified stock
P100720	Safety Valve Type 75	Electronic Parts	✓			
P100800	Office Supplies - Paper	Office Expense	✓			
P100801	Headphones	Office Expense	✓			
P100900	Monitor (17 Inch)	IT Equipment	✓			
P110211	Radiator Standard	Boiler, Heater, Assemblies	✓			
P110401	Wood Burning Stove	Consumer Products	✓	✓		
P110405	Radiator Standard, Packaged	Boiler, Heater, Assemblies		✓	✓	
P110500	Handset	Consumer Products	✓	✓		
P110801	Packaging material	Packaging Material	✓			
P110220	Stove Pipe Set	Consumer Products	✓	✓		
P110310	Brown Coal Briquette, 1 palette	Consumer Products	✓	✓		
P120101	Compressor	Electronic Parts	✓	✓		
P120102	Burner Element	Boiler, Heater, Assemblies	✓	✓		
P120103	Tankless Water Heater	Boiler, Heater, Assemblies	✓	✓		
P120104	Thermostat	Electronic Parts	✓	✓		
P200016	Software License	Software Products	✓	✓		

### 3.7 Services

#### Naming convention for services

- LOB Services: **S200101**, **S200102**, ...

Service ID	Description	Service Category	Service Type	Purchase	Sales
S200101	Senior Consultancy	Services		✓	✓
S200102	Junior Consultancy	Services		✓	✓
S200103	Project Management	Services		✓	✓
S200104	Development	Services		✓	✓
S200105	Training	Services			✓
S200106	Computer Equipment Installation	Services			✓
S200107	Workshop	Services			✓
S200108	Repair	Services		✓	✓
S200109	Repair (at Service Center)	Services		✓	✓
S200016	Software License	Software Products			✓
S200001	Setup in Production	Services			
S200002	Produce in Production	Services			
S200120	Disturbance Allowance	Travel			✓
S200121	Travel Time	Travel			✓
S200230	First Level Support	Services		✓	✓
S200231	Second Level Support	Services			✓
S200130	Rent	Services		✓	
S100100	Gas Boiler Installation	Services			✓
S200525	Maintenance	Software Products			✓
S200111	Travel Miles	Travel		✓	
S200112	Travel Lodging	Travel		✓	
S200109	Repair (at Service Center)	Service Center Service			✓

## 3.8 Entitlements

### Naming convention for Entitlements

- LOB Services: E300101, E300102, ...

Product ID	Description	Product Category	Sales
E300101	Platinum Support - 7x24	Entitlements	✓
E300102	Gold Support - 7x18	Entitlements	✓
E300103	Technical Remote Support	Entitlements	✓
E300104	Technical On-site Consulting & Audits	Entitlements	✓
E300201	Contract for Server Support	Entitlements	✓
E300202	Contract for Software Training	Entitlements	✓

### 3.9 Location Layout and Bill of Material

#### 3.9.1 Location Layout

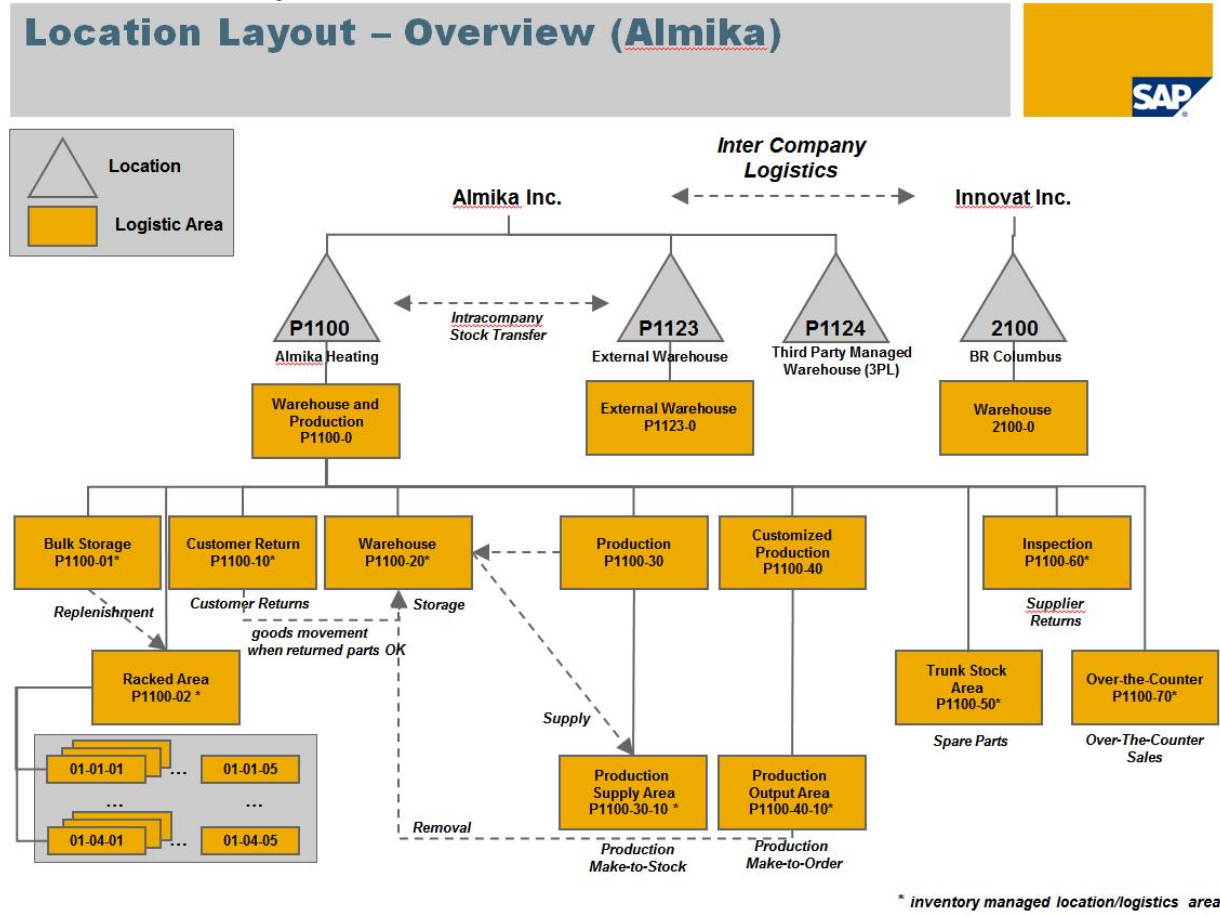

### 3.9.2 Bill of Material Overview

#### BOM Structure - Make-to-Stock

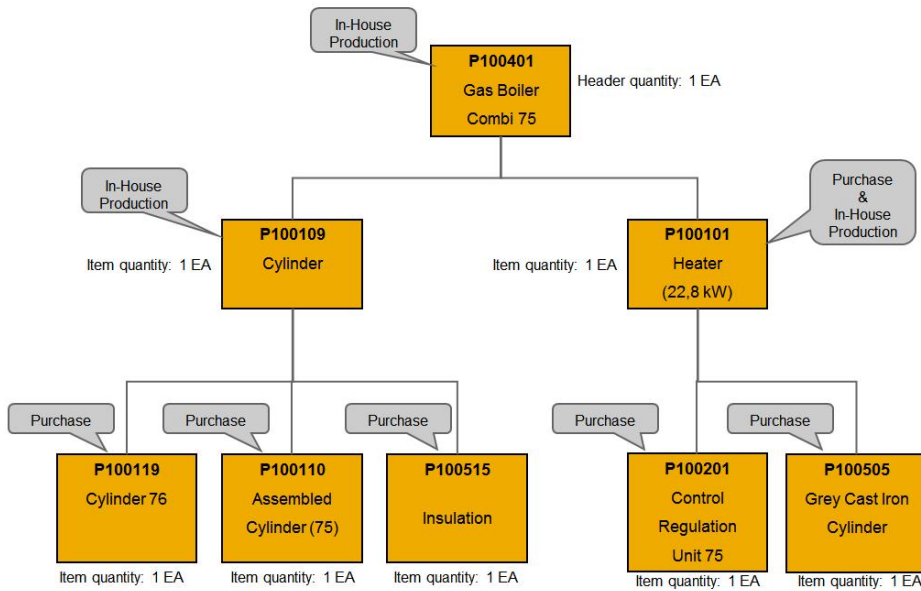

#### BoM Structure – Order-to-Cash (Make-to-Order)

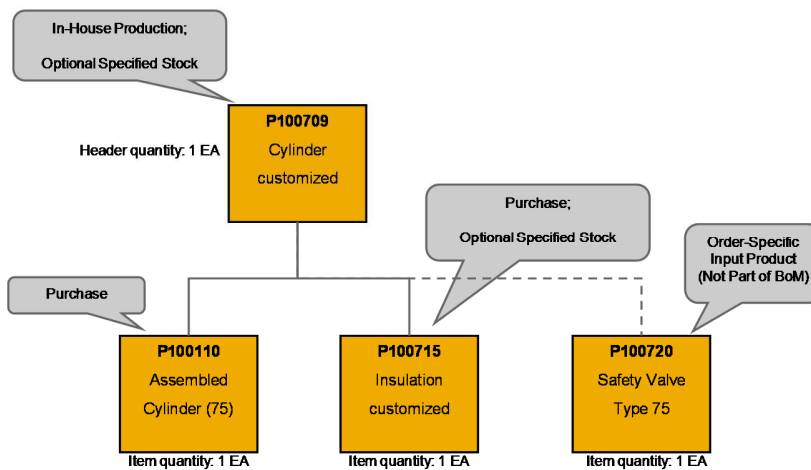

## BOM Structure – Quality Assurance

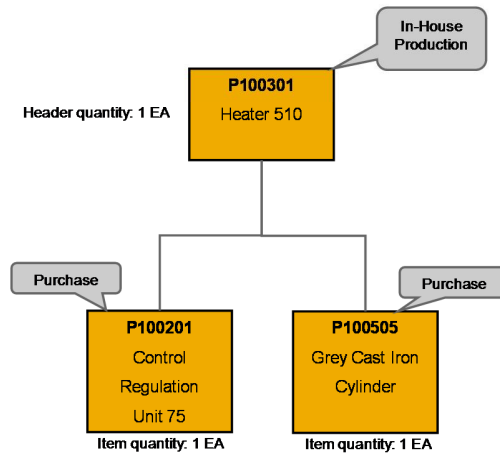

## 4 Transactional Data in the System

The following section tells you which transactional data exists for specific demo cases.

### 4.1 Document Flow for SRM

Request for quotation (product P110401):

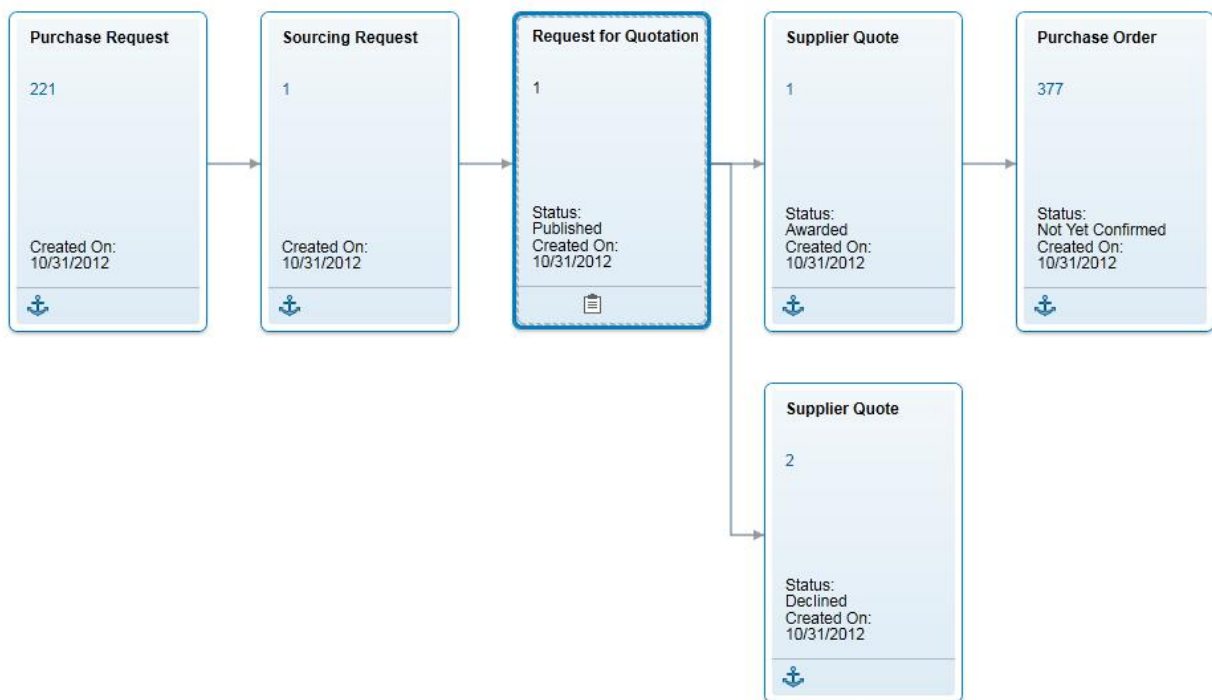

## 4.2 Document Flow for CRM

See tag 999

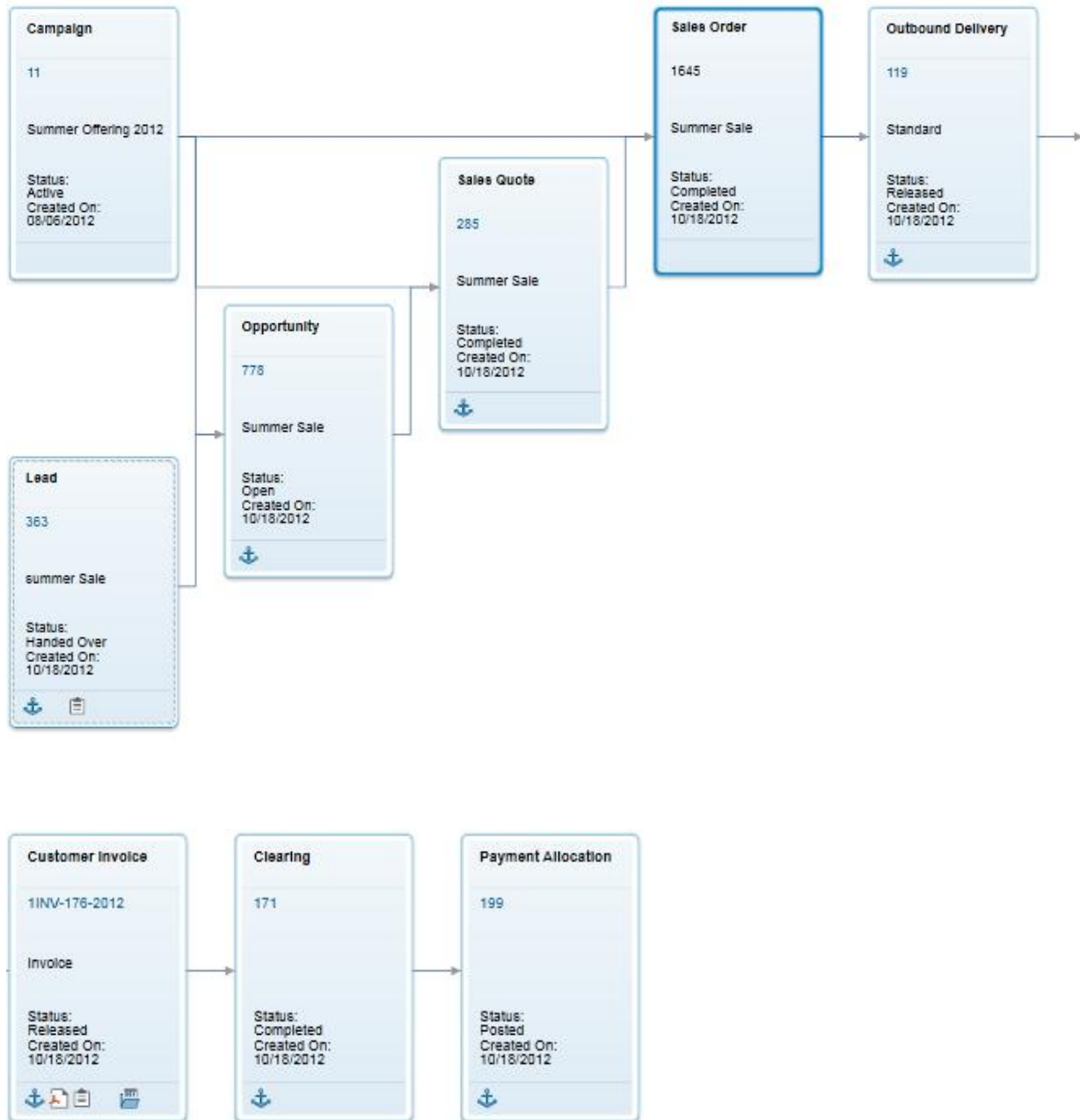



### 4.3 Document Flow for Projects

See project 200\_PRO\_250



## 5 Sample Data for Specific Functions

### 5.1 Outbound Delivery with UPS/FedEx Tracking Number

Outbound Deliveries with link to FedEx/UPS.

Outbound Delivery ID	Demo Usage
120	Delivery with FedEx Tracking ID
121	Delivery with UPS Tracking ID

### 5.2 Demand Plans with Forecasts

Demand Plans for which the statistical forecasts have already been run.

Demand Plan ID	Demand Plan Description	Forecasting Method / Demo Usage
DP_10	DP Seasonal Demand	Seasonal Linear Regression
DP_11	DP Growing Demand	Linear Regression
DP_12	DP Average Demand	Weighted Moving Average

### 5.3 Sales Order for Genealogy Inquiry

The following sales order is the starting point to perform a Genealogy Inquiry (Sales Order → Outbound Delivery → Identified Stock (Finished Good) → Production Confirmation → Identified Stock (Input Product) → Warehouse Confirmation → Purchase Order → Supplier

Sales Order ID	Demo Usage
1202	Starting Point for Genealogy Inquiry

### 5.4 Customer Contract

The following table contains the customer contracts:

Contract ID	Contract Description	Account	Items	Demo Usage
1	Server Q1000 tech support	CS200123	E300101 E300103	
2	Heater problem	CP100110	S200108	

## 5.5 Supplier Contracts

The following table contains the contracts available for purchasing:

Supplier ID	Contract ID	Description	Material	Demo Usage
1000001	25	Innovat Senior Consulting	S200101	
1000001	14	IC-Stock Transfer	P110220	
S100200	11	Castings	P100505 P100109 P100110 P100515 P100101 P100201 P100119	
S100200	24	Purchasing P100111 - S100200	P100111	
S100200	12	Cleaning and Washing Spread	P100436	
S100300	18	Purchasing Control Regulation Unit 80	P100206	
S100400	15	Purchasing for Gasboiler	P100515 P100110 P100101 P100201 P100505 P100213 P100119	
S100400	16	Purchasing Wood Burning Stove	P110401	
S100401	13	Third-Party Order with S100401	P100202	
S100500	35	Supplier Service Center	S200109	
S100500	21	PC Equipment	P100900	
S100600	23	Paper and Printing	P100800 P100801	
S100700	17	Purchasing Coal Briquette	P110310	
S200100	22	Consulting Service	S200101 S200102 S200105	

## 5.6 Material for Cycle Counting

Materials which are marked for Cycle Counting.

Material ID	Material Description	Demo Usage
P100101	Heater (22.8 KW)	Cycle Counting
P100110	Assembled Cylinder (75)	Cycle Counting
P100111	Heater 76	Cycle Counting

## 5.7 Product Model Showing all Product Property Formats

Product Model that contains various properties with different format.

Product Model ID	Product Model Description	Demo Usage
PM_709	Customer Specific Cylinder	Product Model with Properties of Type Code, Boolean, Quantity , Free Text

## 5.8 Product Specification

Pre-defined Product Specifications

Product Specification ID	Product Specification Description	Product ID	Properties	Comprehensive Where-Used List
PS_P100709	Product Specification for P100709	P100709	No	No
PS_P100710	Product Specification for P100710	P100710	No	No
PS_P100709_A	Silverstar - Model A	P100709	Yes	Yes

## 5.9 Projects

Fully maintained projects

Project ID	Project Name	Demo Usage
200_PRO_250	Analyzer Implementation	Project for Mile Stone Billing – full Document flow
200_PRO_150_US	Analyzer Implementation	Test Drive Project – Monitor your Project

## 5.10 Project Templates

Pre-defined Template

Template ID	Template Name
200_PRO_0	Analyzer Implementation

## 5.11 Predefined Mass Data Run Objects (MDROs)

The following MDROs are defined and activated in the system, but not yet scheduled.

Work Center	MDRO Type	MDRO ID	MDRO Description	Properties
Customer Invoicing	Invoice Run	IR-1	IR-1	Automatic Release
Internal Logistics	Replenishment Run	RR-1	RR-1	Replenishment Rule, Location: P1100
Internal Logistics	Removal Run	RR-2	RR-2	Removal Rule, Location: P1100
Inventory Management	Material Cost Estimate Run	2012-10-00000001	MCE-1	Company 1000
Inventory Management	Material Cost Estimate Release Run	2012-10-00000001	MCER-1	Company 1000
Outbound Logistics Control	Confirmation Update Run	CU-1	CU-1	
Outbound Logistics Control	Release Due Deliveries Run	RDD-1	RDD-1	
Supply Planning	Planning Run	PR-1	PR-1	Delete all Planning Proposals that are not firm

## 5.12 G/L Account Mapping

Following mapping between G/L Accounts is applied in case where Journal Entry Voucher are to be posted in all Sets of Books and the Sets of Books have different Chart of Accounts. If the Set of Book is not entered on the UI, the Journal Entry Voucher will be posted to all Sets of Books for the company.

G/L Accounts of the local Chart of Accounts of the leading Set of Book are mapped to G/L Accounts of the additional Set of Books (IFRS).

G/L Account (US GAAP)	Mapped Account (IFRS)
450230 - Material Consumptions	450230 - Material Consumptions
500100 - Marketing Expenses	500100 - Marketing Expenses
500300 - Travel Expense	500300 - Travel Expense
500400 - Advertising Expense	500400 - Advertising Expense
511000 - Insurance Expense	511000 - Insurance Expense
512000 - Repair and Maintenance Expense, Office	512000 - Repair and Maintenance Expense, Office
517000 - Telephone & Telecommunication Expense	517000 - Telephone & Telecommunication Expense
517200 - Office Supplies	517200 - Office Supplies
517300 - Training Expense	517300 - Training Expense
517900 - Other Expense	517900 - Other Expense
518000 - Service Expenses (External)	518000 - Service Expenses (External)





## 6.2 Approval Limits

Approval Type	Limit	Currency
Shopping Cart Approval	500	USD
Sales Quote	100,000.00	USD
Purchase Order Approval	20,000.00	USD
Supplier Invoice Approval	5,000.00	USD
Incoming Payment Approval	0	USD
Outgoing Payment Approval	10,000.00	USD
Payment Deduction Approval (Incoming)	50.00	USD
Expense and Reimbursement Approval	500.00	USD

### Multi-Level Approvals:







When Buying IT Equipment, (Product Category 102 - for example Sales02P orders an Laptop) via Self-Service – Shopping Cart, you need first an direct Approver which is the IT-Manager (Administration01). The second approver is the Manager responsible for the Cost Center (Sales01P)

### Purchase Order Item Level Approval:

An purchase order Re-approver is triggered when there is a changed line item of a purchase order: Quantity, Price or Cost Assignment require an Re-Approval of Purchase Orders. In this case the changed item is sent for approval to the line item approver. The process of Re-approval and item approval applies only for non-stock procurement against projects or cost centers.



## Icons

	<b>Caution</b>
	<b>Example</b>
	<b>Tip</b>
	<b>Note</b>
	<b>User ID and User Role</b>
	<b>Work Center and Work Center View</b>

## Copyright

© 2014 SAP SE or an SAP affiliate company. All rights reserved.

No part of this publication may be reproduced or transmitted in any form or for any purpose without the express permission of SAP SE or an SAP affiliate company.

SAP and other SAP products and services mentioned herein as well as their respective logos are trademarks or registered trademarks of SAP SE (or an SAP affiliate company) in Germany and other countries. Please see <http://www.sap.com/corporate-en/legal/copyright/index.epx#trademark> for additional trademark information and notices. Some software products marketed by SAP SE and its distributors contain proprietary software components of other software vendors.

National product specifications may vary.

These materials are provided by SAP SE or an SAP affiliate company for informational purposes only, without representation or warranty of any kind, and SAP SE or its affiliated companies shall not be liable for errors or omissions with respect to the materials. The only warranties for SAP SE or SAP affiliate company products and services are those that are set forth in the express warranty statements accompanying such products and services, if any. Nothing herein should be construed as constituting an additional warranty.

In particular, SAP SE or its affiliated companies have no obligation to pursue any course of business outlined in this document or any related presentation, or to develop or release any functionality mentioned therein. This document, or any related presentation, and SAP SE's or its affiliated companies' strategy and possible future developments, products, and/or platform directions and functionality are all subject to change and may be changed by SAP SE or its affiliated companies at any time for any reason without notice. The information in this document is not a commitment, promise, or legal obligation to deliver any material, code, or functionality. All forward-looking statements are subject to various risks and uncertainties that could cause actual results to differ materially from expectations. Readers are cautioned not to place undue reliance on these forward-looking statements, which speak only as of their dates, and they should not be relied upon in making purchasing decisions.